

Smiley Touch™ Technical Data Sheet

HONT1000 | HONT1100 | HONT3100 | HONT4100

1. SMILEY TOUCH

User interface

Weight without battery: 1.3 kg / 2.9 lbs

Battery type: li-ion (HONT1000 | HONT1100), li-po (HONT3100 | HONT4100)

Battery weight: 120 g / 0.26 lbs

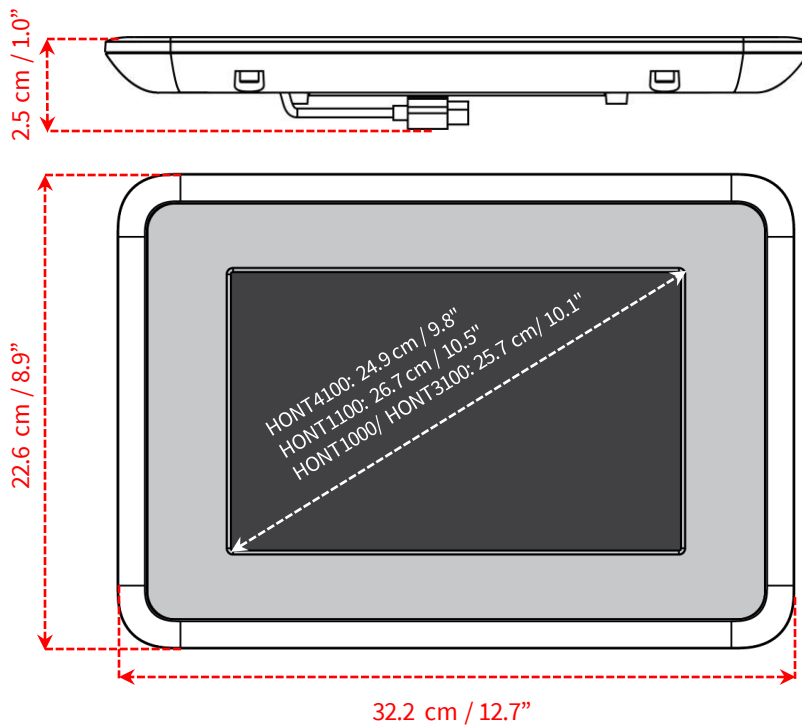

Smiley Touch package includes:

- Smiley Touch user interface
- Attention sign holder
- V sign arm
- Thumb nut
- Hex screws
- Smiley Touch Frame
- Leg Plate
- Hex key
- Square baseplate
- Power supply
- Power cable
- Assembly Guide
- Cardboard box

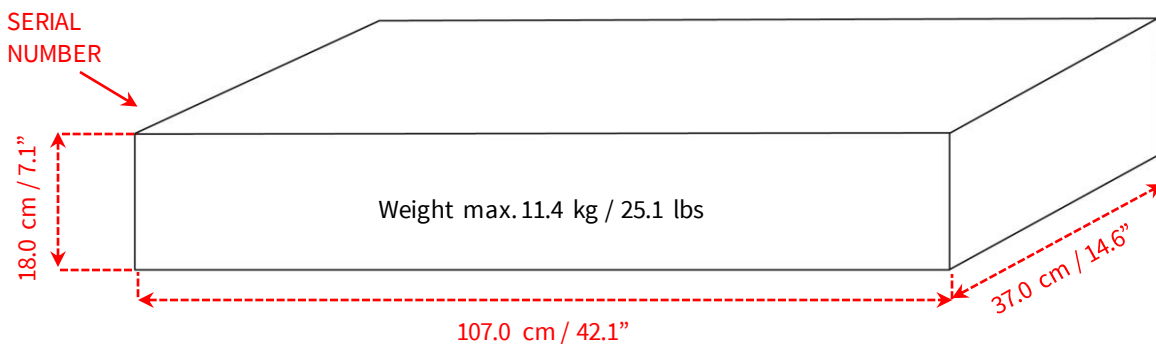

Smiley Touch™ Technical Data Sheet

HONT1000 | HONT1100 | HONT3100 | HONT4100

2. SMILEY TOUCH WITH A BRANDING LEG PLATE

Smiley Touch with a branding leg plate

Weight: 8.7 kg / 19.2 lbs

Total height: 130.1 cm / 51.2"

Attention sign size: A4 / Letter

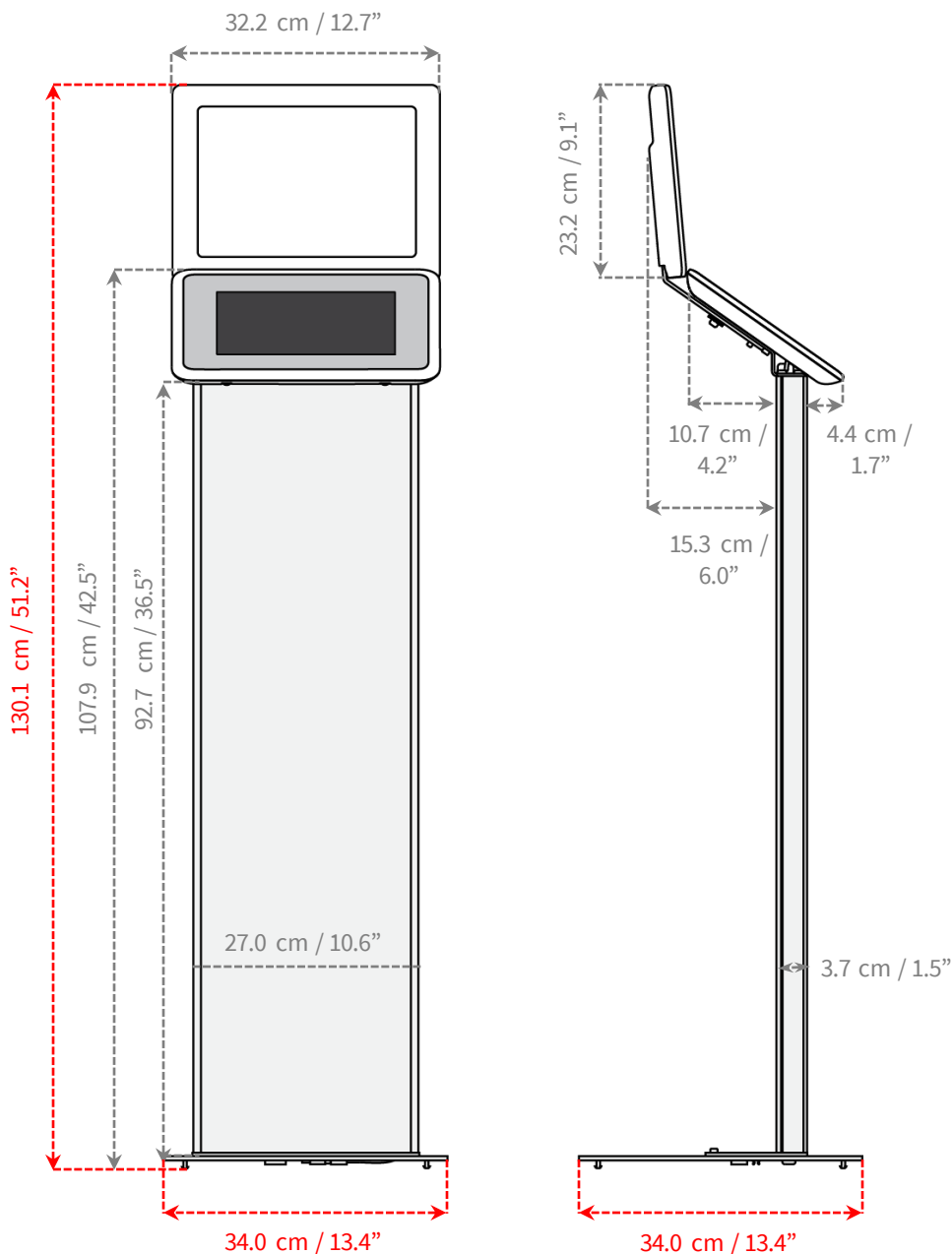

Smiley Touch™ Technical Data Sheet

HONT1000 | HONT1100 | HONT3100 | HONT4100

3. SMILEY TOUCH WALL

User interface

Weight without battery: 1.3 kg / 2.9 lbs

Battery type: li-ion (HONT1000 | HONT1100), li-po (HONT3100 | HONT4100)

Battery weight: 120 g / 0.26 lbs

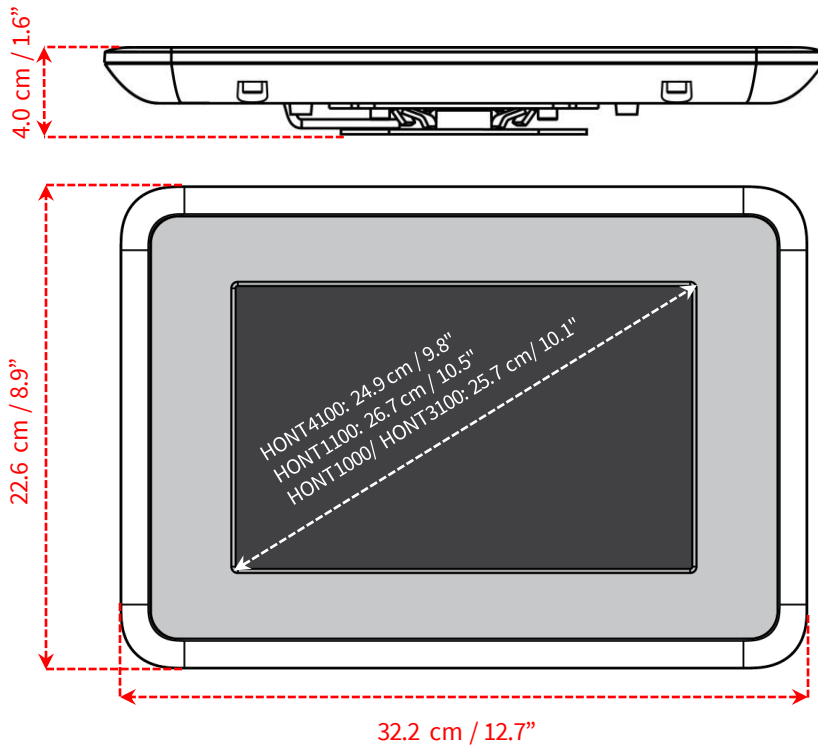

Smiley Touch Wall package includes:

- Smiley Touch user interface
- Wall mount
- Power supply
- Power cable
- Assembly Guide
- Cardboard box

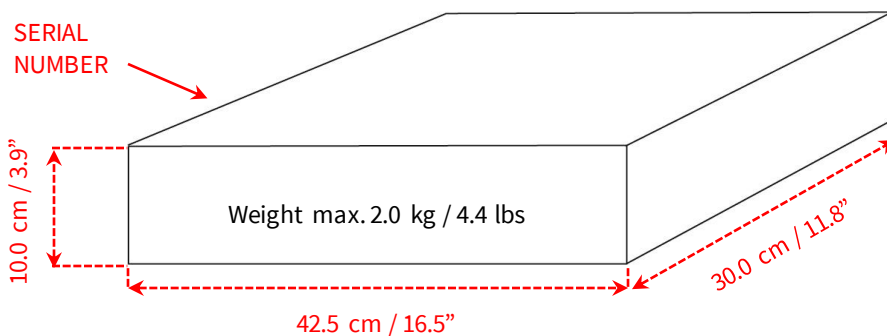

Smiley Touch™ Technical Data Sheet

HONT1000 | HONT1100 | HONT3100 | HONT4100

4. SMILEY TOUCH TABLE

User interface

Weight without battery: 1.3 kg / 2.9 lbs

Battery type: li-ion (HONT1000 | HONT1100), li-po (HONT3100 | HONT4100)

Battery weight: 120 g / 0.26 lbs

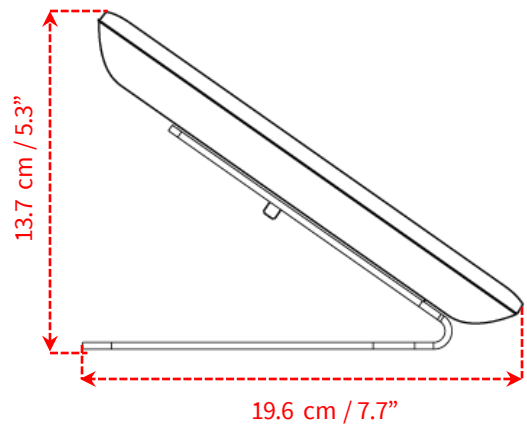
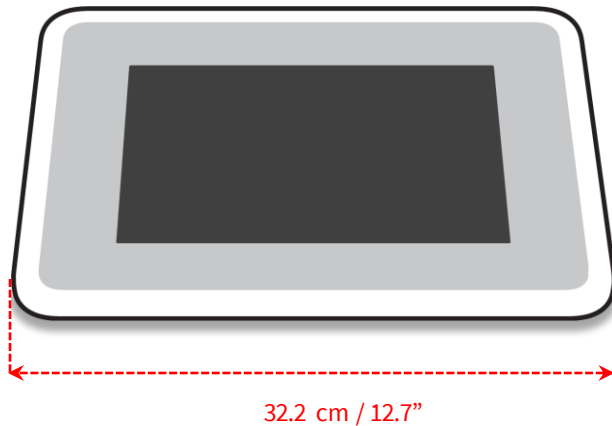

Smiley Touch Wall package includes:

- Smiley Touch user interface
- Table mount
- Power supply
- Power cable
- Assembly Guide
- Cardboard box

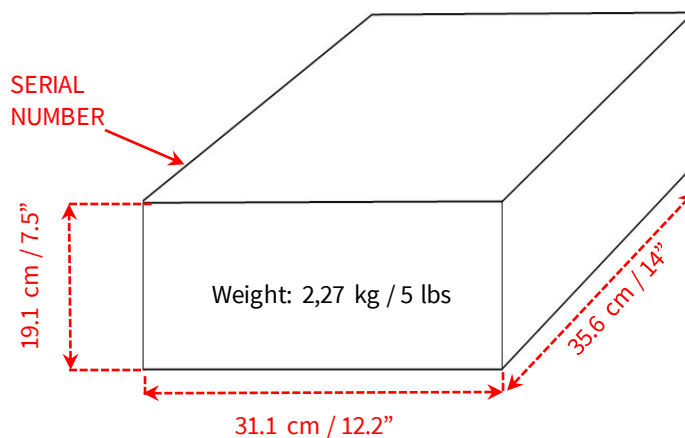

Smiley Touch™ Technical Data Sheet

HONT1000 | HONT1100 | HONT3100 | HONT4100

4. TECHNICAL SPECIFICATIONS

MODEL	HONT1000	HONT1100	HONT3100	HONT4100
Approvals	CE, FCC, RoHS	ROHS, CE, FCC, RCM, BIS, ENACOM, IMDA, ICASA, NCC, TRA	RoHS, CE, FCC, ICASA, TRA, NCC	RoHS, CE, FCC
Power charger input	100-240V~0.35A 50-60Hz	100-240V~0.50A 50-60Hz	100-240V~0.30A 50-60Hz	100-240V~0.30A 50-60Hz
Device power input	5.0Vdc 2.0A	9.0Vdc 1.67A or 5.0Vdc 2.0A	5.0Vdc 1.55A	5.0Vdc 1.55A
Max. power consumption	10W	15W	7.75W	7.75W
Battery	7300mAh Li-ion	7300mAh Li-ion	6150mAh Li-po	7040mAh Li-Po
Operating temperature	Ambient +5 to +35 C / +41 to +95 F			
IP class	IP30			
Flammability	UL94 V0			
Frequency Bands	HONT1000	HONT1100	HONT3100	HONT4100
2G GSM	GSM 850, GSM 900, DCS1800, PCS 1900	GSM 850, GSM 900, DCS1800, PCS 1900		
3G UMTS	B1 (2100), B2 (1900), B5 (850), B8 (900)	B1 (2100), B2 (1900), B4 (AWS), B5 (850), B8 (900)		
4G FDD LTE	B1 (2100), B3 (1800), B5 (850), B7 (2600), B8 (900), B20 (800)	B1 (2100), B2 (1900), B3 (1800), B4 (AWS), B5 (850), B7 (2600), B8 (900), B12 (700), B17 (700), B20 (800), B28 (700), B66 (AWS-3)		
4G TDD LTE	B40 (2300)	B38 (2600), B40 (2300)		
Dimensions (HxWxD):				
With Branding leg plate	130.1 x 34.0 x 34.0 cm / 51.2 x 13.4 x 13.4"			
Wall	22.6 x 32.2 x 4.0 cm / 8.9 x 12.7 x 1.6"			
Table	13,1x32,2x20,2cm/5.2x12.7x8"			
Weight:				
With Branding leg plate	8.7 kg / 19.2 lbs			
Wall	1.3 kg / 2.9 lbs			
Table	2,27 kg / 5 lbs			
Package dimensions (HxWxD):				
With Branding leg plate	18.0 x 107 x 37 cm / 7.1 x 42.1 x 14.6"			
Wall	10.0 x 42.5 x 30.0 cm / 3.9 x 16.5 x 11.8"			
Table	19.1 x 35.6 x 31.1 cm / 7.5 x 14 x 12.2"			
Package weight:				
With Branding leg plate	11.4 kg / 25.1 lbs			
Wall	2.0 kg / 4.4 lbs			
Table	2.7 kg / 5.9 lbs			